



GDF Document Protection Safes

Certified 2 hour fire protection



The premium GDF record protection safes are specially designed to safeguard valuable documents from burglary and fire. These safes come with European certified TUV electronic locking, and are designed and certified to 2 hour fire protection.

SECURITY FEATURES

- Digital lock and keypad
- External hinges with internal anti-pry dead bar.
- Fire resistant material filled door and body
- 120 minutes fire resistant
- Durable quality paint finish
- Adjustable Shelving
- Pre-drilled anchoring holes

PRODUCT SPECIFICATIONS

Model	EXTERNAL (MM)			INTERNAL (MM)			Weight (kg)	Volume (litres)	Shelves (adj)	Fire rating (mins)	REC. RETAIL PRICE \$	
	Height	Width	Depth	Height	Width	Depth					excl.GST	incl.GST (10%)
GDF 200EH	1630	775	650	1450	595	440	388	380	4	120		
GDF L300EH	1685	1126	700	1505	946	490	540	698	4	120		

DEPTH MEASUREMENT DOES NOT INCLUDE THE HANDLE, KEYPAD OR HINGES. PLEASE ALLOW 50MM.
Due to Guardall constantly striving to deliver better products; sizes and colours may vary slightly.

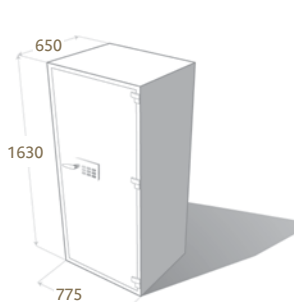

● GDF 200EH

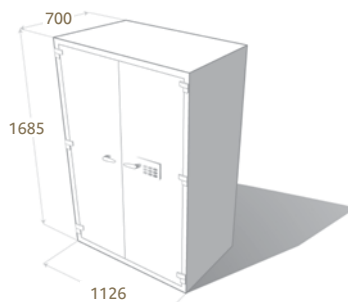

● GDF L300EH